

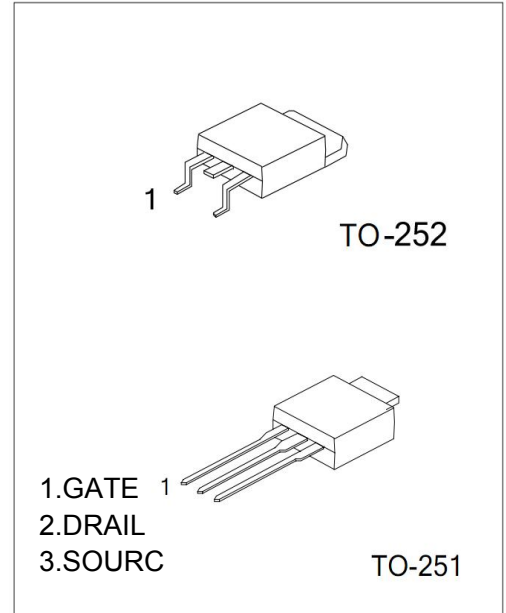

MK3055 N-Channel 30-V(D-S) Power MOSFET

V(BR)DSS	RDS(on)MAX	ID
30 V	24mΩ@ 10 V	15A
	34mΩ@ 4.5 V	

Equivalent Circuit:



General Description:

The high voltage MOSFET uses an advanced termination scheme to provide enhanced voltage-blocking capability without degrading performance over time. In addition , this advanced MOSFET is designed to withstand high energy in avalanche and commutation modes . The new energy efficient design also offers a drain-to-source diode with a fast recovery time. Designed for high voltage, high speed switching applications in power suppliers, converters and PWM motor controls , these devices are particularly well suited for bridge circuits where diode speed and commutating safe operating areas are critical and offer additional and safety margin against unexpected voltage transients.

MARKING: MK 3055 MKD / U ****

MK-logo / (D-252) / (U-251) / *- Date

FEATURE:

- ※ Power switching application
- ※ Hard switched and high frequency circuits
- ※ Uninterruptible power supply
- ※ Fully characterized avalanche voltage and current
- ※ Excellent package for good heat dissipation
- ※ Good stability and uniformity with high EAS

SYMBOL:

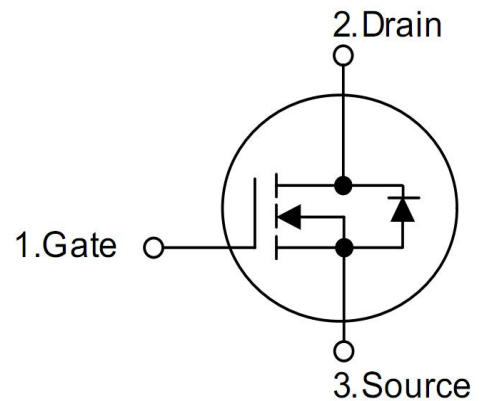

Maximum ratings (Ta=25°C unless otherwise noted)

Parameter	Symbol	Value	Unit
Drain-Source Voltage	VDS	30	V
Gate-Source Voltage	VGS	±20	
Continuous Drain Current	ID	15	A
Pulsed Diode Curren	IDM	50	
Power Dissipation	PD	28	W
Thermal Resistance from Junction to Ambient (t≤5s)	RθJA	125	°C/W
Operating Junction	TJ	150	°C
Storage Temperature	TSTG	-55~+150	



MOSFET ELECTRICAL CHARACTERISTICS

Static Electrical Characteristics (Ta = 25 °C Unless Otherwise Noted)

Parameter	Symbol	Test Condition	Min	Typ	Max	Unit
Static						
Drain-source breakdown voltage	V(BR)DSS	VGS = 0V, ID = 250μA	30			V
Gate-source threshold voltage	VGS(th)	VDS = VGS, ID = 250μA	1		3	V
Gate-source leakage	IGSS	VDS = 0V, VGS = ±20V			±100	nA
Zero gate voltage drain current	IDSS	VDS = 30V, VGS = 0V			1	μA
Drain-source on-state resistancea	RDS(on)	VGS = 10V, ID = 8A		14.5	25	mΩ
		VGS = 4.5V, ID = 4A		18	37	mΩ
Forward transconductancea	gfs	VDS = 4.5V, ID = 15A		5.0		S
Diode forward voltage	VSD	IS = 1A, VGS = 0V		0.8	1.5	V
Dynamic						
Input capacitance	Ciss	VDS = 25V, VGS = 0V, f = 1MHz		260		pF
Output capacitance	Coss			144		pF
Reverse transfer capacitanceb	Crss			13		pF
Total gate charge	Qg	VDS = 25V, VGS = 10V, ID = 8A		5.4		nC
Gate-source charge	Qgs			1.3		nC
Gate-drain charge	Qgd			3.6		nC
Gate Resistance	Rg	f = 1MHz		1.5		
Switchingb						
Turn-on delay time	td(on)	VDD = 15V RL = 3Ω, ID = 8A, VGEN = 10V, Rg = 3.4Ω		3.6		ns
Rise time	tr			19.8		ns
Turn-off delay time	td(off)			13		ns
Fall time	tf			3.2		ns
Drain-Source Diode Characteristics						
Continuous Source-Drain Diode Current	IS				15	A
Pulsed Diode forward Curren	ISM				50	A

Note :

1. Repetitive Rating : Pulse width limited by maximum junction temperature.
2. Surface Mounted on FR4 Board, t < 5 sec.
3. Pulse Test : Pulse Width ≤ 300μs, Duty Cycle ≤ 2%.
4. Guaranteed by design, not subject to production testing.



PACKAGE OUTLINE DIMENSIONS :

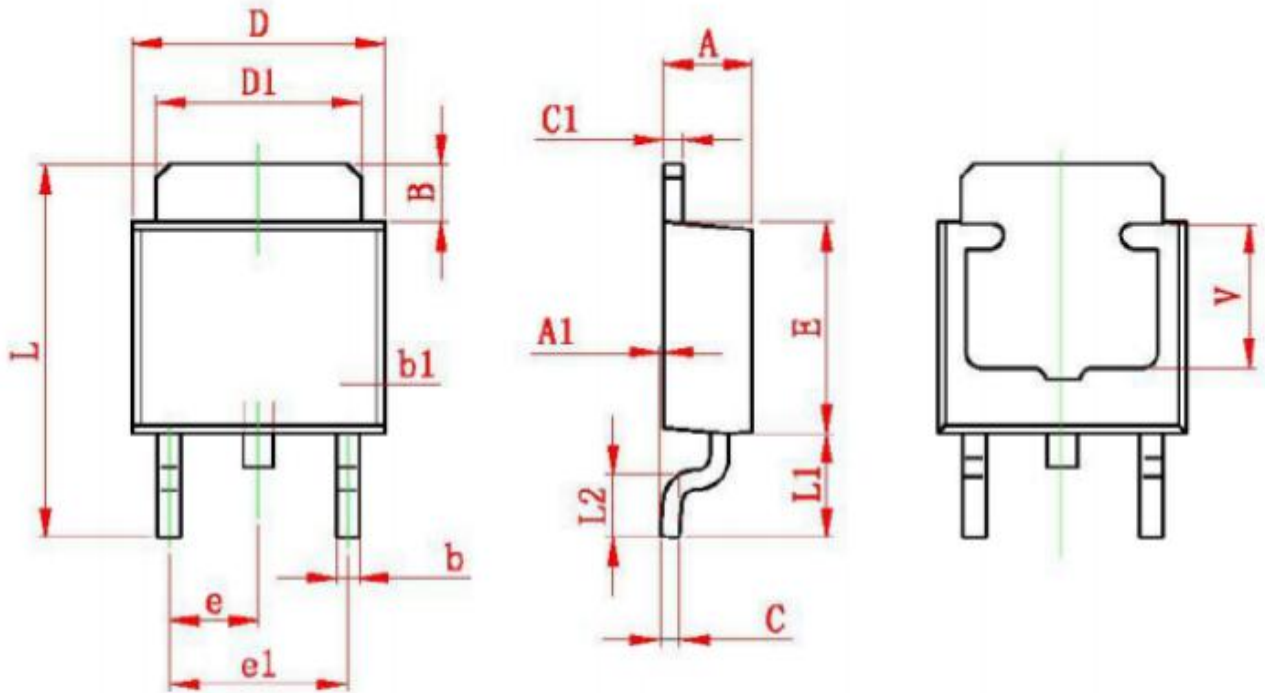

Symbol	Dimensions In Millimeters		Dimensions In Inches	
	Min	Max	Min	Max
A	2.200	2.400	0.087	0.094
A1	0.000	0.127	0.000	0.005
B	1.350	1.650	0.053	0.065
b	0.500	0.700	0.020	0.028
b1	0.700	0.900	0.028	0.035
c	0.430	0.580	0.017	0.023
c1	0.430	0.580	0.017	0.023
D	6.350	6.650	0.250	0.262
D1	5.200	5.400	0.205	0.213
E	5.400	5.700	0.213	0.224
e	2.300 TYP		0.091 TYP	
e1	4.500	4.700	0.177	0.185
L	9.500	9.900	0.374	0.390
L1	2.550	2.900	0.100	0.114
L2	1.400	1.780	0.055	0.070
V	3.80 REF		0.150 REF	



PACKAGE OUTLINE DIMENSIONS :

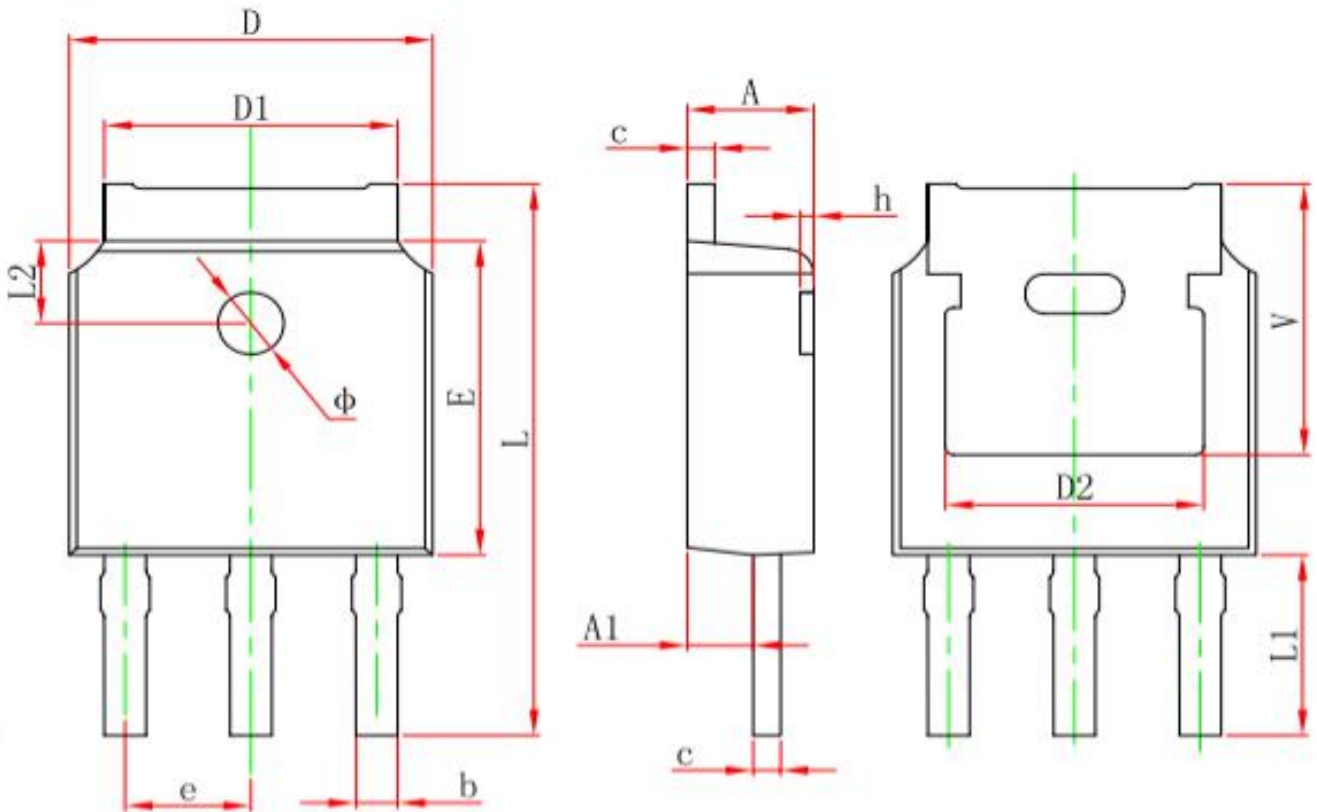

Symbol	Dimensions In Millimeters		Dimensions In Inches	
	Min.	Max.	Min.	Max.
A	2.200	2.400	0.087	0.094
A1	0.860	1.160	0.034	0.046
b	0.660	0.860	0.026	0.034
c	0.460	0.580	0.018	0.023
D	6.500	6.700	0.256	0.264
D1	5.100	5.460	0.201	0.215
D2	4.830 REF.		0.190 REF.	
E	6.000	6.200	0.236	0.244
e	2.186	2.386	0.086	0.094
L	10.400	11.000	0.409	0.433
L1	3.300	3.700	0.130	0.146
L2	1.600 REF.		0.063 REF.	
Φ	1.100	1.300	0.043	0.051
h	0.000	0.300	0.000	0.012
V	5.350 REF.		0.211 REF.	