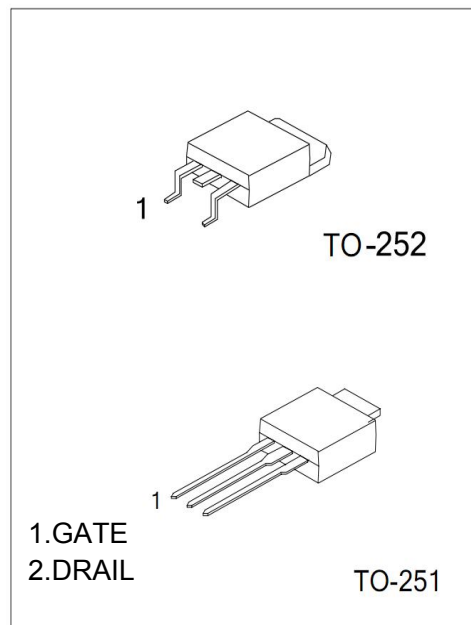

**MK15N10 N-Channel 100-V(D-S) Power MOSFET**

V(BR)DSS	RDS(on)MAX	ID
100 V	100mΩ@ 10 V	15A
	120mΩ@ 4.5 V	

Equivalent Circuit:**General Description:**

The high voltage MOSFET uses an advanced termination scheme to provide enhanced voltage-blocking capability without degrading performance over time. In addition, this advanced MOSFET is designed to withstand high energy in avalanche and commutation modes. The new energy efficient design also offers a drain-to-source diode with a fast recovery time. Designed for high voltage, high speed switching applications in power suppliers, converters and PWM motor controls, these devices are particularly well suited for bridge circuits where diode speed and commutating safe operating areas are critical and offer additional and safety margin against unexpected voltage transients.

FEATURE:

- ※ Power switching application
- ※ Hard switched and high frequency circuits
- ※ Uninterruptible power supply
- ※ Fully characterized avalanche voltage and current
- ※ Excellent package for good heat dissipation
- ※ Good stability and uniformity with high EAS

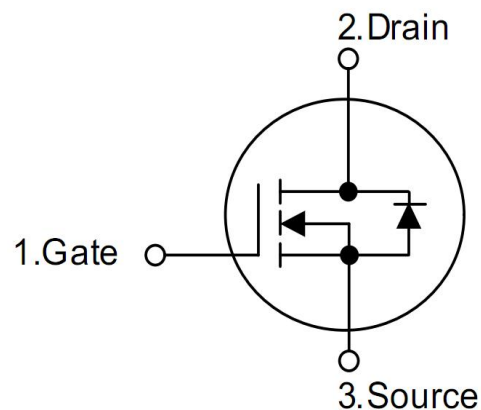
SYMBOL:**Maximum ratings (Ta=25°C unless otherwise noted)**

Parameter	Symbol	Value	Unit
Drain-Source Voltage	VDS	100	V
Gate-Source Voltage	VGS	±20	
Continuous Drain Current	ID	15	A
Pulsed Diode Curren	IDM	59	
Power Dissipation	PD	35	W
Thermal Resistance from Junction to Ambient (t≤10s)	RθJA	100	°C/W
Operating Junction	TJ	150	°C
Storage Temperature	TSTG	-55~+150	



MOSFET ELECTRICAL CHARACTERISTICS

Static Electrical Characteristics (Ta = 25 °C Unless Otherwise Noted)

Parameter	Symbol	Test Condition	Min	Typ	Max	Unit
Static						
Drain-source breakdown voltage	V(BR)DSS	VGS = 0V, ID = 250μA	100			V
Gate-source threshold voltage	VGS(th)	VDS =VGS, ID = 250μA	1		3	V
Gate-source leakage	IGSS	VDS =0V, VGS = ±20V			±100	nA
Zero gate voltage drain current	IDSS	VDS = 60V, VGS =0V			1	μA
Drain-source on-state resistancea	RDS(on)	VGS = 10V, ID = 8A		93	100	mΩ
	RDS(on)	VGS = 4.5V, ID = 5A		96	120	mΩ
Diode forward voltage	VSD	IS= 8A, VGS=0V		0.8	1.3	V
Dynamic						
Input capacitance	Ciss	VDS = 15V, VGS =0V, f=1MHz		710		pF
Output capacitance	Coss			58		pF
Reverse transfer capacitanceb	Crss			23		pF
Total gate charge	Qg	VDS = 80V, VGS = 10V, ID = 10A		24		nC
Gate-source charge	Qgs			4.6		nC
Gate-drain charge	Qgd			7.6		nC
Gate Resistance	Rg	f=1MHz		1.6		
Switchingb						
Turn-on delay time	td(on)	VDD= 50V RL= 2Ω, ID = 10A, VGEN= 10V,Rg= 1Ω		14		ns
Rise time	tr			33		ns
Turn-off delay time	td(off)			39		ns
Fall time	tf			7		ns
Drain-Source Diode Characteristics						
Continuous Source-Drain Diode Current	IS				15	A
Pulsed Diode forward Curren	ISM				35	A

Note :

1. Repetitive Rating : Pulse width limited by maximum junction temperature.
2. Surface Mounted on FR4 Board, t < 10 sec.
3. Pulse Test : Pulse Width≤300μs, Duty Cycle ≤ 2%.
4. Guaranteed by design, not subject to production testing.



PACKAGE OUTLINE DIMENSIONS :

TO-252 PACKAGE OUTLINE DIMENSIONS

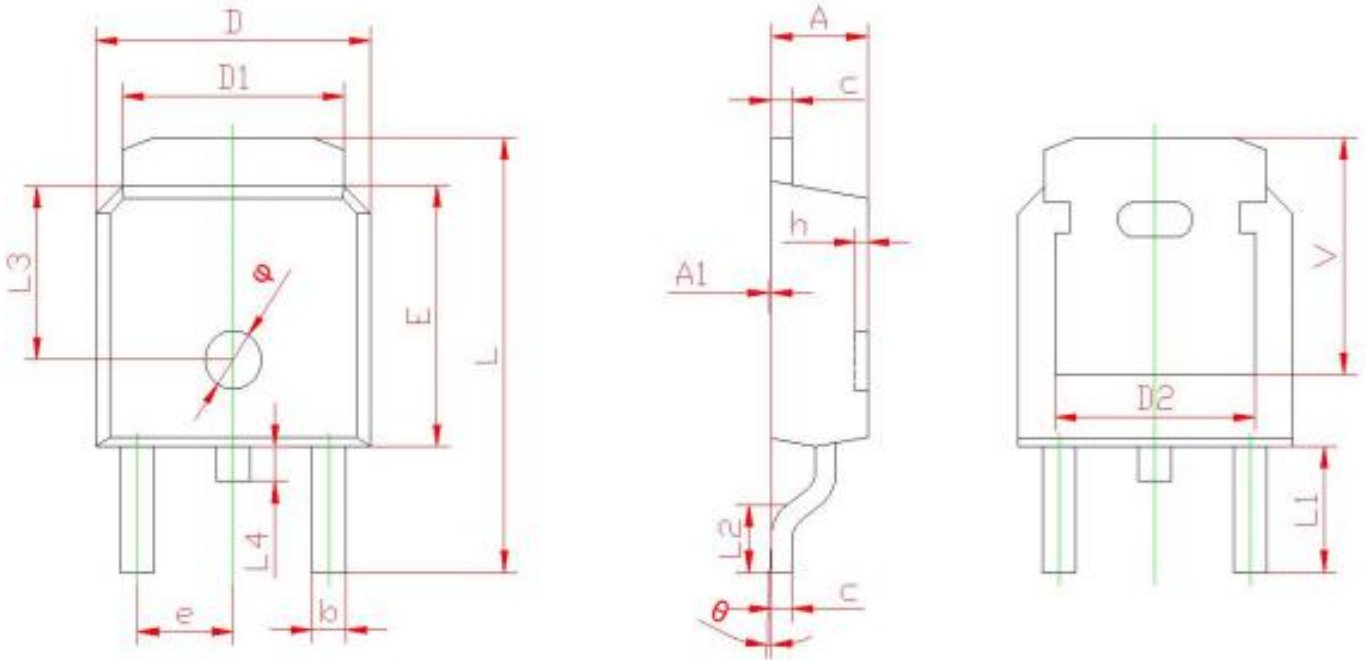

Symbol	Dimensions in Millimeters		Dimensions in Inches	
	Min.	Max.	Min.	Max.
A	2.200	2.400	0.087	0.094
A1	0.000	0.127	0.000	0.005
b	0.660	0.860	0.026	0.034
c	0.460	0.580	0.018	0.023
D	6.500	6.700	0.256	0.264
D1	5.100	5.460	0.201	0.215
D2	4.800 REF		0.189 REF	
E	6.000	6.200	0.236	0.244
e	2.186	2.386	0.086	0.094
L	9.800	10.400	0.386	0.409
L1	2.900 REF		0.114 REF	
L2	1.400	1.700	0.055	0.067
L3	4.00 REF		0.157 REF	
L4	0.600	1.000	0.024	0.039
φ	1.200	1.400	0.043	0.051
θ	0°	8°	0°	8°
h	0.000	0.300	0.000	0.012
V	5.500 REF		0.217 REF	



PACKAGE OUTLINE DIMENSIONS :

TO-251 PACKAGE OUTLINE DIMENSIONS

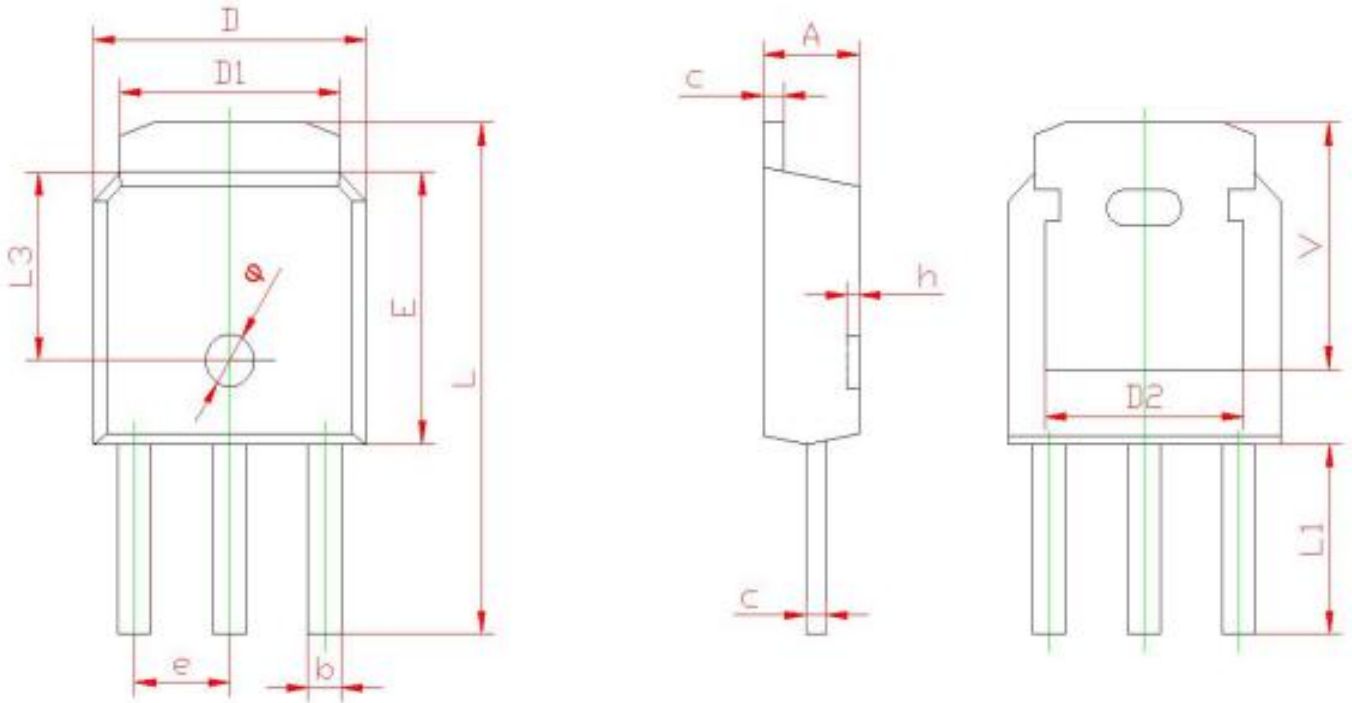

Symbol	Dimensions In Millimeters		Dimensions In Inches	
	Min.	Max.	Min.	Max.
A	2.200	2.400	0.087	0.094
b	0.660	0.860	0.026	0.034
c	0.460	0.580	0.018	0.023
D	6.500	6.700	0.256	0.264
D1	5.100	5.460	0.201	0.215
D2	4.800 REF		0.189 REF	
E	6.000	6.200	0.236	0.244
e	2.186	2.386	0.086	0.094
L	11.100	11.700	0.437	0.461
L1	4.300 REF		0.170 REF	
L3	4.00 REF		0.16 REF	
φ	1.200	1.400	0.043	0.051
h	0.000	0.300	0.000	0.012
V	5.500 REF		0.217 REF	